

GT-B / GTSD-B Twin Wheel Caster (Threaded Bolt Type)

Features

- Easy operation to lock both wheel and swivel in one step
- Wheels are coated in polyurethane which absorbs vibration and gives an extra smooth and quiet movement

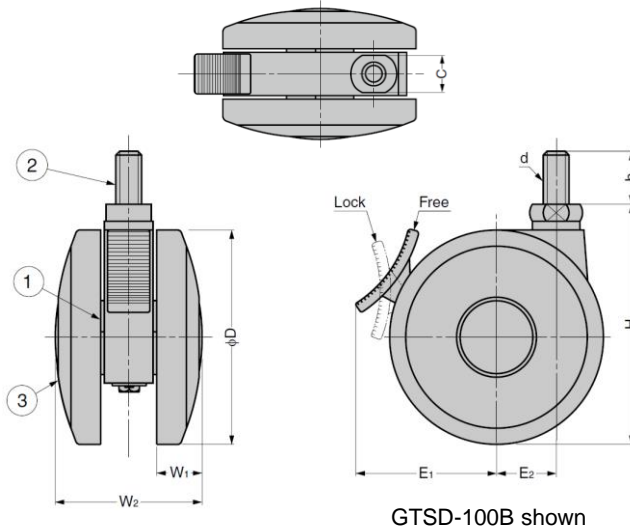

No.	Part Name	Material	Finish/Colour
①	Body	PA	Light Grey
②	Threaded Bolt	Steel	Clear Zinc Chromate (Trivalent)
③	Wheel	PA + PUR	Light Grey

Part No.	Type	D	W ₁	W ₂	H	h	E ₁	E ₂	C	d	Load Capacity (per piece)	
GTSD-75B	With Brake	76	19	61	86	20	45	21	17	M10	784 N	80 kg
GT-75B	Without Brake											
GTSD-100B	With Brake	100	20	69	117.5	25	64	28	21	M12 × 1.25	980 N	100 kg
GT-100B	Without Brake											

GFS Design Caster

Features

- 8 cover colours available
- The cover is removable
- With lock level to lock the wheel
- Wheel diameter is $\varnothing 75$

Notes

- Be careful not to scratch the cover when removing it

